

HYDRAULIC IMPACT WRENCH

DHW 3034 - DHW 301 - DHW 501

kg 7,6

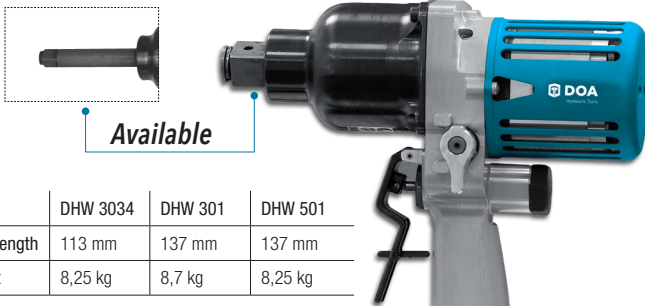

cod.	DHW 3034	DHW 301	DHW 501
Anvil Length	113 mm	137 mm	137 mm
Weight	8,25 kg	8,7 kg	8,25 kg



- *Torque control: adjustable torque up to 3000-5000 Nm, for the hardest bolts.*
- *3-jaw hammer mechanism type*
- *Motor cover with heat dissipation*
- *Rotation inverter*
- *Handle entirely made in Ergal*
- *Ergonomic handle with integrated oil flow*
- *Mechanical trigger with safety lever*

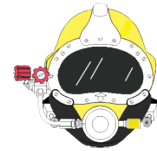

Available in
underwater version

Ideal for: mechanical and industrial workshops, infrastructures and railway applications, oil&gas, mining and cold workplaces when no air supply is available.

TECHNICAL CHARACTERISTICS	DHW 3034	DHW 301	DHW 501
Weight (kg)	7,6	7,7	8,8
Square drive	3/4"	1"	1"
Bolt range	M14 - M24	M18 - M33	M18 - M36
Max torque	3000 Nm	3000 Nm	5000 Nm
Free speed	2800 rpm	2800 rpm	1700 rpm
Max oil flow	10-20L/min	10-20L/min	10-20L/min
Length	421 mm	288,8 mm	323,4 mm
Side to center	62 mm	57 mm	57 mm

